**ESDI Model 110100-A
MDB MultiPrice Water Vend Controller
Operation and Installation Manual
(Also see Programming & Service Manual)**

WARNING ! ELECTRICAL SHOCK HAZARD !

AUTHORIZED PERSONNEL ONLY.

EXPOSED 120 VAC ON CIRCUIT BOARD.

**THE CIRCUIT BOARD HAS MANY EXPOSED AREAS
THAT ARE AT 120 VAC. CONTACTING ANY OF THESE AREAS
CAN CAUSE BODILY HARM OR DEATH.**

**DISCONNECT POWER BEFORE SERVICING
AND MAKING ANY CONNECTIONS**

July 17, 2015

By: M. A. Stern

Electronic Systems Design, Inc.

1010 North Maclay Ave., San Fernando, California 91340 USA
Phone: (818) 365-0864 Fax: (818) 365-1308 Web Site: www.esdi.net

Table of Contents

OPERATING INSTRUCTIONS & FEATURES

1.0.	<u>General Description:</u>	Page 4
2.0.	<u>Controller Features:</u>	Page 4-5
	2.1. Maximum Run Timer	
	2.2. Metered or Timer Controlled Vend	
	2.3. UV Flush Options	
	2.4. Pause Option	
	2.5. Bottle Rinse Option	
	2.6. Door (Nozzle Cover) Option	
	2.7. Lockout Option	
3.0.	<u>Modes of Operation:</u>	Page 5-6
	3.1. Water Vending Machine – The Basic Machine	
	3.2. Water Vending Machine – With Bottle Rinse Feature	
	3.3. Water Vending Machine – With Start / Pause Feature	
	3.4. Water Vending machine – With Door Feature	
4.0.	<u>Payment Transaction:</u>	Page 6-8
	4.1. Credit Accumulation	
	4.2. Display Activity	
	4.2.1. Idle State	
	4.2.2. Switch Echo	
	4.2.3. Vend Process	
	4.2.4. Change Payment	
	4.2.5. Use Correct Change LED	
	4.2.6. Power-Up and Reset Initialization	
	4.3. Internal Vend and Cash Counters	
	4.4. Free Vend	
	4.5. Switch Selections	

INSTALLATION & WIRING

5.0.	<u>Electrical Specifications:</u>	Page 8
	5.0.1. Coin / Bill Acceptor Interface	
	5.0.2. Relay Outputs	
	5.0.3. Water Sensor Interface	
	5.0.4. Vend Accuracy / Repeatability	
	5.0.5. Power Requirements	
	5.0.6. Circuit Board Assembly Size	
	5.0.7. Operating Temperature	
	5.0.8. Storage Temperature	
	5.0.9. Relative Humidity	
5.1.	<u>Inputs:</u>	Page 8-10
	5.1.1. Flow Meter Input	
	5.1.2. Low Water (Low Pressure) Input	
	5.1.3. Lockout Input (UV Shut Down)	

- 5.1.4. Vend Switch Input
 - 5.1.4.1. Vend Switch with Pause Option
- 5.1.5. Bottle Rinse Switch Input
- 5.1.6. Selector Switch Inputs
- 5.1.7. Power Input

6.0. Outputs:

Page 10-11

- 6.1. Pump Relay Output
- 6.2. Credit Lamp Relay Output
- 6.3. Bottle Rinse Valve Output
- 6.4. Door Relay Output

7.0. Connectors:

Page 11-12

- 7.1. TB1 Control Inputs
- 7.2. TB2 Control Outputs
- 7.3. TB3 Power Input and Output – 24VAC
- 7.4. Display Board
- 7.5. J5 Remote Display Board (Optional)
- 7.6. J3 Comm Port (Optional)
- 7.7. TB11 Slave Board Interface

SETUP & PROGRAMMING

8.0. Switches & Indicators:

Page 12-14

- 8.1. Reset Switch
- 8.2. Free Vend Switch
- 8.3. No Vend Switch
- 8.4. Program Switch
- 8.5. Calibrate Switch
- 8.6. Vend Quantity Calibration Procedure
- 8.7. Program Mode
- 8.8. Power Indicator
- 8.5. System Status Display

9.0. Options (DIP Switch Selectable):

Page 15

- 9.1. Flow Meter/Internal Timer Selection
- 9.2. UV Flush Cycle Option Enable
- 9.3. Rinse Bottle Option Enable
- 9.4. Door Option Enable
- 9.5. Pause Mode Option Enable
- 9.6. Lockout Mode

10.0. Programming and Service:

See separate ESDI Model 110100 Programming and Service Manual

Radiated Frequency Protection:

It is recommended that the controller board be shielded from radiated frequencies using a metal cover. It is further recommended that service personnel or persons gaining access to the internals of the machine, observe proper ESD control measures to prevent damage to the machine. It may be necessary for the OEM to place a line filter in the machine if external or internal sources cause conducted noise levels.

MDB MultiPrice Water Vend Controller ESDI Model 110100A Installation & Operation Manual

Operating Instructions & Features

1.0. General Description:

The ESDI Model 110100A MDB MultiPrice Water Vend Controller is an electronic assembly that controls all of the functions necessary to operate an unsupervised bulk water vending machine. It is designed to vend six (6) volumes of water, each having its own price. The six volumes are easily set by the user during a calibration procedure. The Model 110100A interfaces to any payment device that is in compliance with NAMA's "International Multi-Drop Bus Interface Standard" (October 19, 1993), such as the COINCO 9302-GX coin changer, bill acceptors, prepaid cards, and credit cards.

A display provides visual feedback to the customer through a four digit 7-segment LED's, and two discrete LED's that indicate "Use Correct Change", and "Make Alternate Selection". This display is on a separate circuit board that mounts to the front of the machine.

An additional single digit display located on the ESDI 110100A control board provides feedback to the technician on the operation and status of the controller.

The ESDI 110100A is expandable up to 12 products, and with the use of additional water vending slave boards, can control up to 4 vend stations using a single coin mech and bill acceptor. Each slave board vends an additional three products, so the 12 inputs can be grouped as 4 vendors, each vending 3 volumes of water. Please see data sheet or web site for a variety of vending possibilities & options.

2.0. Controller Features:

2.1. Maximum Run Timer:

The controller has an internal maximum run timer for the water vending only. It is factory set to approx. 90 seconds beyond the normal vending time. If this time is exceeded, the controller will stop vending, go "Sold Out", and will not accept coins. The Status Display will indicate "E". A manual reset (power off, wait 5 seconds, then power on) will restart the controller.

If the Maximum run time is exceeded, and the Low Water switch is active at that time, the controller will reset itself automatically 10 minutes after the Low Water switch has become inactive.

2.2. Metered or Timed Controlled Vending Options:

This controller allows the option of using either an inline water flow sensor, or an on-board timer to accurately control the amount of water. The board can accommodate many types of flow sensors, however, the maximum pulse count for a single vend is 65,535 counts, and the maximum vend time is 7 minutes.

By far the best method for achieving accurate vending is to use an inline water flow sensor. However, it is possible to get accurate vending using the internal timer, as long as the water flow remains constant throughout the entire vending cycle.

2.3. UV Flush Option (Hot Water Removal):

An optional UV flush cycle is provided to periodically discard hot water that is left standing in the UV lamp assembly, and refresh the vending system in general. This water is discharged out the

vend nozzle and into the drain. The flush cycle runs for a period of 3 seconds. When enabled, a flush cycle will occur as follows:

- Upon each power-up and manual reset.
- Upon returning from a Low Water condition.
- Upon returning from a Lockout condition.
- Periodically, every 30 minutes after the last vend.

The flush cycle will not run if there is credit pending, if the system is in the process of vending water, during a Lockout condition, a Low Water condition, or a UV Lamp failure. During the flush cycle, the controller will go "Sold Out" and will not accept any coins. The Status Display will indicate "F" during the flush cycle. The flush cycle runs for a period of 3 seconds.

2.4. Pause Option (Stop & Continue):

When the Pause option is selected, the Vend switch will also serve as a Pause switch. When this option is selected, pressing the Vend switch during vending will cause the vending to stop for a period of up to one minute. If the Vend switch is again pressed within one minute, vending will continue. If one minute is exceeded, vending will terminate, and reset. The pause can be used intermittently until the selected volume of water has vended.

2.5. Bottle Rinse Option:

The Bottle Rinse option provides the ability to offer your customers a Bottle Rinse prior to filling their bottles. This Bottle Rinse switch becomes enabled after purchase credit has been received, and the selection has been made. This switch will become disabled after the bottle rinse cycle has completed, or after a vending cycle has begun.

Upon activating the Bottle Rinse switch, the Rinse valve relay will turn on and the pump will start. The amount of water used for the rinse cycle is approx. equal to 1/16th of the selected volume of water that is being purchased. The amount of 1/16th volume is automatically calculated for each item during the calibration process and stored in memory. When using a separate Rinse Valve, the AUX output will be used to control the Vend Valve. When not using a separate Rinse Valve, the Vend Valve will connect to the pump output.

2.6. Door Option : (Not available on Model 110100A-Master/Slave Controller)

The Door option is for vending machines using a door to cover the water vend nozzle. If the Door option has been selected, the door relay will activate two seconds before the pump starts, and reset one second after the pump stops. This is not available on the Master control board, as that board uses this output to set the calibration mode on the Slave boards.

2.7. Lockout Option :

This option works with the Lockout input. If selected, and a lockout condition occurs, the controller will stop any vending immediately and go to lockout. The controller will NOT automatically reset and will require a manual reset from a technician. This is normally the option used when a UV Lamp, or Flood Switch controls lockout. This option is provided because a bad UV lamp can flicker on and off many times thus becoming unreliable. The same can happen with a Flood Switch, which can also open and close frequently.

3.0. Modes of Operation:

3.1. Water Vending Machine – The Basic Machine:

1. Customer deposits money.
2. Customer presses Selection Switch, selecting water volume and price.
3. Money balance is shown on display.

4. The "Start Vend" switch will illuminate. (If used)
5. Customer presses the "Start Vend" switch. Without this switch, vending will begin upon making selection.
6. The "Start Vend" switch illumination will turn off. (If used)
7. The Vend Valve & Pump will turn on and run until the proper amount of water has vended.
8. If there is still a money balance, an additional selection can be made, or the coin return button can return the balance in coins.

3.2. Water Vending Machine – With Rinse Feature:

1. Customer deposits money.
2. Customer presses Selection Switch, selecting water volume and price.
3. Money balance is shown on display.
4. "Rinse" switch and "Vend" switch will illuminate.
5. Customer presses one of these switches. "Rinse" if he wants to rinse out his bottle, or "Vend" if he does not want a rinse and wants to proceed with the vending.
6. If Rinse is selected, the Rinse Valve & Pump will turn on and dispense an amount of water equal to 1/16th the volume being purchased.
7. Customer swirls water around bottle and pours out into the drain. Or, a separate rinse nozzle placed at the bottom will allow water to shoot up and automatically drain when the bottle is placed upside down in the vending area.
8. Customer returns bottle to vend station & presses "Vend" switch to proceed with vend.
9. The "Rinse" and "Vend" switch illumination will turn off.
10. The Vend Valve & Pump will turn on until the proper amount of water has vended.
11. If there is still a money balance, an additional selection can be made, or the coin return button can return the balance in coins.

3.3. Water Vending Machine – With Start/Pause Feature:

1. Customer deposits money.
2. Customer presses Selection Switch, selecting water volume and price.
3. Money balance is shown on display.
4. The "Start/Pause" switch will illuminate.
5. Customer presses the "Start/Pause" switch.
6. The "Start/Pause" switch illumination will turn off.
7. The Vend Valve & Pump will turn on and run until the proper amount has vended.
8. If during the vending cycle the customer presses the "Start/Pause" switch, the Vend Valve & Pump will turn off and remain off for one minute before resetting.
9. The "Start/Pause" switch will again illuminate.
10. If during one minute pause the customer presses the "Start/Pause" switch, the Vend Valve & Pump will turn on and run until the proper amount of water has vended.
11. The "Start/Pause" switch illumination will turn off.
12. This can be repeated multiple times until the proper amount of water has vended.
13. If there is still a money balance, an additional selection can be made, or the coin return button can return the balance in coins.

3.4. Water Vending Machine – With Door Feature:

1. The nozzle door will open one (1) second before the pump starts, and will close three (3) seconds after the pump stops. A Door Switch input provides feedback to report the door is open and it is safe to vend.

4.0. Payment Transaction:

4.1. Credit Accumulation:

Credit may be accumulated through a coin changer, bill acceptor or card reader mechanism. Card reader credit cannot be mixed with coin and bill credit during a single transaction or vend.

Credit acceptance will be disabled when the accumulated credit equals or exceeds the highest priced item. Cash box coins and bills are enabled on an individual basis according to the inventory coins available. Cash box coins and bills will be enabled if the coinage currently held in the changer's inventory tubes is greater than the coin or bill to be accepted, plus the credit currently accumulated by the controller.

If all of the configured selections are sold out, credit acceptance will be disabled, "No Sale" will flash on the display. If the amount of card credit available exceeds the maximum displayable credit (dependent on the scale factor), the maximum credit will be displayed.

4.2. Display Activity:

4.2.1. Idle State:

The display will show "0000" when no switch or vend activity is present. **Program switch must be ON for coins to be manually ejected from changer tubes.**

4.2.2. Switch Echo:

When a selection switch is pressed the display will show the price of the selected item.

4.2.3. Vend Process:

After a switch entry is made the controller will determine if sufficient credit is available and the status of the selection. If the accumulated credit is greater than or equal to the selection price and the selection is available, a selection attempt will be made for that selection. If credit is less than the selection price, the price will be displayed for 3 seconds or until a new selection switch is pressed. If the selection is not available "No Sale" will flash for 2 seconds along with the "Make Alternative Selection" LED, or until a new selection is made.

4.2.4. Change Payment:

A least coin payout algorithm will be implemented. Program switch must be ON for coins to be manually ejected from changer tubes.

4.2.5. Use Correct Change LED:

If the level of the changer's least value coin tube is below the lowest sensor, the "Use Correct Change" LED will be illuminated continuously.

4.2.6. Power-Up and Reset Initialization:

Following a power-up, or reset condition, the display will test all of the LED segments by displaying patterns. This will continue until the peripherals and controller have been initialized.

4.3. Internal Vend and Cash Counters:

Following a successful vend, the vend counter will be incremented by one and the cash counter will be incremented by the price of the selection vended. Counter rollover occurs at 99,999,999 and \$999,999.99 respectively. (Note: Test vends are not included in the counter totals.)

4.4. Free Vend:

The "free vend" option allows the customer to free vend items in the machine with no credit input. The message "FrEE" will be shown on the display and all credit acceptance will be disabled whenever the "free vend" option is enabled. Disabling the "free vend" option will return the controller to the normal sales mode.

Installation & Wiring

5.0 Electrical Specifications:

- 5.0.1. Coin / Bill Acceptor Interface: NAMA Multi-Drop Bus Protocol
COINCO 9302-GX, or equal
- 5.0.2. Relay Outputs (All): Any Voltage up to 120 VAC, 3 Amps Max.
- 5.0.3. Water Sensor Interface: GEMS Turbine Flow Sensor, FT-110,
Part No. 173935 (3800 Pulses per Gallon).
- 5.0.4. Vend Accuracy / Repeatability: ± 0.5 %.
- 5.0.5. Power Requirements:
- Board & MDB Peripheral: 24 VAC, 60/50 Hz, 2.5 Amp Nominal.
(Note some MDB peripherals may require more current, up to 4 Amps max)
 - Vend Pump & Valves: 24-120 VAC 60/50 Hz, 3 Amps Max.
 - Operating Voltage Range: 22 VAC - 32 VAC, 50/60 Hz.
 - Power Transformer: 120VAC, 60/50 Hz Input, 24VAC Output
- 5.0.6. Circuit Board Assembly Size: 7.5" X 7.5".
- 5.0.7. Operating Temperature: 32° F to 150° F (0° to 65° C)
- 5.0.8. Storage Temperature: -22° F to 167° F (-30° to 75° C)
- 5.0.9. Relative Humidity: 20% to 95% non-condensing
- 5.0.10 Fuse (F1): Board Fuse, 3 Amp SloBlo, 24VAC, Type 5X20 mm.

5.1. Inputs:

All inputs must be isolated contact closures. DO NOT APPLY ANY EXTERNAL VOLTAGES TO INPUTS, OR BOARD MAY BE DAMAGED.

5.1.1. Flow Meter/Sensor Input: (Leave open if not used)

Used for metered vend only. This input is for an external inline water flow sensor. As water passes through the flow sensor it sends out pulses. The controller counts these pulses and compares it to the calibrated amount predetermined in memory. The controller can accommodate many different types of water meters, however, the maximum count per a single vend is 65,535 counts. One that works very well is the GEMS Turbine Flow Sensor, FT-110 Series, P/N 173935 (3800 Pulses per Gallon max). Power in the form of +5VDC is provided to power the flow sensor.

5.1.2. Low Water (Low Pressure) Input:

Is there water to vend? This input is connected to a water level sensor located at the lowest level of the reservoir. We recommend that the level sensor be placed such that there is at least 5 gallons of water remaining. If a low water condition is detected when the controller is idle, the controller will go to "No Sale", and will not accept coins. If a low water condition is detected while vending, the controller will complete the vending and go "No Sale". The controller will automatically reset when the low water condition is no longer present. An open circuit on this input indicates a low water condition. If Option switch 8 "Option 2" is on, low water will shut down all vend stations until water is present, otherwise only the Master board will shut down..

5.1.3. Lockout Input (UV Shut Down):

Is UV lamp working? The lockout input allows an external device to disable the controller, such as an external water purity monitor, a flood switch, UV lamp, or any other device supervising the controller operation. A contact closure on this input will allow the controller to operate normally and an open will disable the controller. If this input is not used, place a jumper between Lockout and Common.

The Lockout mode switch controls how this input will operate.

In the OFF position: If a lockout condition occurs while the controller is vending, it will first complete the vending and then go to lockout. If a lockout condition occurs when the controller is idle, it will lockout immediately. The controller will automatically reset and be ready to vend when the lockout is no longer present.

In the ON Position: If a lockout condition occurs, it will stop any vending immediately and go to lockout. The controller will NOT automatically reset and requires a manual reset from a technician. This is normally the position when a UV Lamp, or Flood Switch controls lockout.

When the controller is in lockout, it will go "Sold Out" and will not accept any coins. The Status Display will indicate "U" when in lockout.

For UV lamp monitoring, choose a UV lamp assembly with an internal circuit that monitors the lamp and has an isolated relay output to indicate a failure. This relay output should be connected to the Lockout Input, or in series with any other lockout device. Contact closure = UV good.

5.1.4. Vend Switch Input:

The Vend Switch Input is connected to a switch on the front of the machine. This switch is used to start vending. This switch becomes enabled after money is placed in the machine, and the selection has been made. If you want the machine to vend immediately upon making the selection, and do not want to use the Vend Switch, then simply turn ON Option switch "OP 1". For calibration purposes, connect the "Vend SW" output located at TB11-1 on the rear of the board to the "Vend Sw" input located on the front of the board. The Selection switch will act as the vend switch during calibration, and vending will begin upon making selection. This connection can remain in place. The Vend Switch is required for the Bottle Rinse Cycle and the Pause options.

5.1.4.1. Vend Switch With Pause Option:

When the Pause option is selected, the Vend switch also serves as a Pause-Continue switch. With the Pause option enabled, pressing the Vend switch during vending will cause the vending to stop for a period of one minute. If the Vend switch is again pressed during the Pause, vending will continue. If one minute is exceeded, vending will terminate, and will not continue. The pause can be used intermittently until the selected volume of water has vended.

5.1.5. Bottle Rinse Switch Input: (Leave open if not used)

The Bottle Rinse Switch input is connected to a switch on the front of the machine. This switch is used to start a rinse cycle, if the rinse cycle option has been selected. This switch becomes enabled after money is placed in the machine, and the selection has been made. The user has the choice of proceeding with a bottle rinse prior to starting the vending of water, or ignoring the rinse cycle and going straight to the vending. A Rinse Valve relay output is provided to operate a separate Rinse valve, directing the water through a separate nozzle. If a separate rinse nozzle is not used the rinse water will come from the same vend nozzle. This switch will become inactive after the bottle rinse cycle has completed, and after a vend cycle.

The optional bottle rinse cycle works as follows. Upon activating the Bottle Rinse Switch, the Rinse Valve Relay will turn on and the pump will start. The pump will operate for a period of time and then stop. The amount of water dispensed during the rinse cycle is approx. 1/16th of the volume of water being purchased. This amount is automatically determined by the controller.

5.1.6. Door OK Input: (Not available on Model 110100A-Master/Slave Controller)

Marked "Door OK" this input is presently setup as the Door Position input when used in conjunction with the Door option. A contact closure on this input indicates that the door is "open" and it is safe to turn on the pump. This input is ignored when the Door option is off. If not used for the door position, it can be factory programmed to serve another purpose. Contact factory for more information.

5.1.7. Selector Switch Inputs:

The product selector switches are located on the back of the control board, connector TB10. The selector switch inputs select the water product and volume for vending. A contact closure to "Switch Output" on any of these inputs will select that product. The switches are as follows:

<u>Selection Sw:</u>	<u>Conn-Pin</u>	<u>Description:</u>	
Item 1	TB10-1	Vend Volume 1	Station 1
Item 2	TB10-2	Vend Volume 2	Station 1
Item 3	TB10-3	Vend Volume 3	Station 1
Item 4	TB10-4	Vend Volume 4	Station 1
Item 5	TB10-5	Vend Volume 5	Station 1
Item 6	TB10-6	Vend Volume 6	Station 1
Item 7	TB10-7	Vend Item 7	Need slave Bd.
Item 8	TB10-8	Vend Item 8	Need slave Bd.
Item 9	TB10-9	Vend Item 9	Need slave Bd.
Item10	TB10-10	Vend Item 10	Need slave Bd.
Item11	TB10-11	Vend Item 11	Need slave Bd.
Item12	TB10-12	Vend Item 12	Need slave Bd.
Sw Common	TB1-Pin 11	Selector Switch Common*	

Connect one side of each selector switch to the appropriate input and the other side to "Selector Switch Common" located at TB10-13 & TB10-14, and also located on the front of the board. *Do not connect any of these switches to regular "Common". Each switch must be an isolated momentary pushbutton type, suitable for low current operation.

5.1.8. Power Input:

This input should be connected to a 24 VAC transformer. Operating voltage range is 22 VAC - 32 VAC, 2.5A Minimum, 50/60 Hz. The transformer should be mounted outside the enclosure to prevent excess heat inside the enclosure.

6.0. Outputs:

All outputs are controlled by normally open relays. These relays have normally open (NO) contacts with uncommitted power sources. Connect one side of the relay to the power source HOT, and the other side of the relay to the device being switched. Connect the power source NEUTRAL directly to each device being switched. The relays are rated for 120VAC, 3 amps maximum.

6.1. Pump Relay Output:

This output will connect to either a vend pump, or a vend valve, or both. It will turn ON at the beginning of vending, or rinse cycle, and turn OFF when the vending is completed.

6.2. Credit Lamp Relay Output:

This output will turn ON after the board has received money and a selection has been made. This indicates that credit has been accepted and either vending, or rinse cycle will proceed. This output will remain ON until a vend cycle begins then it will turn OFF. This output can be used to

illuminate both of the Vend and Rinse switches, showing the user that a choice must be made, or just the Vend switch if the Rinse option is not used.

6.3. Bottle Rinse Valve Output:

This output is only active if the Bottle Rinse option has been selected. This output will be ON whenever the rinse switch has been activated. This output can be connected to a Rinse Lamp, and a separate water valve allowing the rinse water to come from a different source and location. This output will return to OFF when the rinse cycle has completed.

6.4. Door Relay Output: (Calibration Output on Model 110100A-Master/Slave Controller)

This output is only active if the Door option has been selected. The Door relay output will turn ON one second before the pump starts, and will turn OFF 3 seconds after the pump stops. It is used to operate a door covering the vend nozzle. See section 5.1.6., Door Position Input for door position feedback.

For the Master control board, this output is used for the Calibration signal that connects to the Slave boards, placing them in the calibration mode. Connect TB3-8 to Slave board Calibration input and TB3-9 to Common.

6.5. Vend Valve Output:

This output is used to control the Vend Valve. The Vend Valve can also be controlled by the Pump output.

7.0. Connectors:

The terminal blocks on the board are pluggable and can be pulled from the board without having to remove the individual wires from the terminal block. It is recommended that all wiring be UL type 1015, 20 AWG, minimum. The power input and pump output should be 18 AWG minimum. The terminal blocks will accommodate up to a 16 AWG wire. The maximum current rating for the connector is 8 Amps.

7.1. TB1 Control Inputs:

All inputs are low voltage (+5VDC). Signals are either open, or closed. We recommend twisted pair shielded wire be used for the Flow Meter wires, with the shield connected to common. DO NOT APPLY ANY VOLTAGES TO THESE INPUTS, OR CIRCUIT BOARD MAY BE DAMAGED.

TB1-1	Signal Common (System Ground)
TB1-2	Lockout Input
TB1-3	Low Water Input
TB1-4	Rinse Switch Input
TB1-5	Vend Switch Input
TB1-6	+5VDC Power
TB1-7	Flow Sensor Input
TB1-8	Signal Common (System Ground)
TB1-9	Door OK (Not on Model 110100A-Master/Slave Controller)

7.2. TB2 Direct Vend Control (Optional):

These are selector inputs that are used only when no payment device is present. Use them to directly control the vending of water. One side of each switch must be connected to TB3-1 "Sel Sw Common".

TB2-1	Vend item 1
TB2-2	Vend item 2
TB2-3	Vend item 3
TB2-4	Vend item 4
TB2-5	Vend item 5

TB2-6	Vend item 6
TB3-1	Selector Switch Common (for selector switches ONLY)

7.3. TB3 Control Outputs:

These are relay outputs. Use them to directly switch the power source, and hardwire the common. For 120VAC switching, use these outputs to switch the Hot side and hardwire the Neutral side off the board.

TB3-1	Selector Switch Common (for selector switches ONLY)
TB3-2	Credit Lamp In
TB3-3	Credit Lamp Out
TB3-4	Pump In
TB3-5	Pump Out
TB3-6	Rinse Valve In
TB3-7	Rinse Valve Out
TB3-8	Door In (On Master board this is the calibration output to all Slaves)
TB3-9	Door Out (On Master board this is the calibration output to all Slaves)
TB3-10	Vend Valve In
TB3-11	Vend Valve Out

7.4. TB5 Circuit Board Power Input 24 VAC:

This circuit board operates from an external 24 VAC power source, and requires less than 1 Amp. The current requirement of the power source, however, depends largely on the MDB peripherals that are used and powered by this board. Therefore, to size the transformer, one must total up the current requirement for all 24VAC devices driven by this board. In most cases, a 24VAC transformer with a 40VA rating should work.

TB5-1	Power Input (24VAC)
TB5-2	Power Input (24VAC_Ret)

7.5. Display Board P1:

The display board mounts on the front of the vending machine to communicate vending information to the customer. It is also used in programming the MDB controller. The display board connects directly to connector P1 located on the back of the board.

7.6. Multi-Drop Bus - Coin/Bill Acceptor Interface P3:

This 7-pin connector (.1" centers) interfaces to the MDB compatible peripherals. The protocol is in compliance with NAMA's "International Multi-Drop Bus Interface Standard". This connects directly to connector P3 located on the back of the board.

7.7. TB11 Slave Board Interface:

This 4 pin terminal block is used to interface to Slave boards in a multiple vend station application. It also provides a Selection switch output signal that can be used during calibration, in place of a separate Vend switch. When used, TB11-1 is connected to TB1-5 Vend switch input.

Setup & Programming

8.0. Switches & Indicators:

8.1. Reset Switch:

This will restart the controller, all errors will be reset and all pending vends will be erased.

8.2. Free Vend Switch:

This switch will place the controller into the Free Vend mode where all items are free. In the Free Vend mode the controller will vend any item selected without requiring deposit of any money. This is a good mode to use when calibrating the vending volume for each item.

8.3. Program Switch:

This switch places the vend board in the Sales Programming mode. A pushbutton switch is also used in the programming mode to Start the programming process. Program switch must be ON for coins to be manually ejected from changer tubes. This switch will reset any sold out items, turn ON for 3 seconds.

8.4. Calibrate Switch:

This switch will place the controller into the Calibration mode. In the Calibration mode the operator can set all of the vend quantities and store them in memory.

8.5. Vend Quantity Calibration Procedure:

The calibration procedure allows the board to be programmed to dispense any 6 volumes of water, and not just limited to 1, 3 and 5 Gallons.

When using a water flow sensor, the maximum count for a single vend is 65,535 counts. This allows a wide variety of flow sensors to be used.

When using the Internal Vend Timer, the maximum vending time is limited to approx. 7 minutes maximum with a .2 second resolution. If vend time is exceeded the Status Display will show "E".

The Calibration is performed as follows:

1. Move "Calibrate Switch" to the On position.
2. Display will show "C" indicating the calibration mode.
3. Set "Free Switch" ON and activate the selection switch to select vend quantity 1. Indicator will show "1".
4. Place a calibrated measuring container in the vend chamber.
5. Activate and hold the "Vend" switch on until the desired amount of water has vended. Release the Vend switch and the vending will stop. The display will show "C" indicating completion. The calibration information will be stored in non-volatile memory. Repeat, or go on to next switch.
6. Activate the selection switch to select vend quantity 2. Indicator will show "2". Repeat steps 4 and 5.
7. Activate the selection switch to select vend quantity 3. Indicator will show "3". Repeat steps 4 and 5
8. Activate the selection switch to select vend quantity 4. Indicator will show "4". Repeat steps 4 and 5.
9. Activate the selection switch to select vend quantity 5. Indicator will show "5". Repeat steps 4 and 5.
10. Activate the selection switch to select vend quantity 6. Indicator will show "6". Repeat steps 4 and 5.
11. When calibration is completed move "Calibrate Switch" to the off position. The controller will reset and start up in the vend mode.

12. Test all vend quantities for accuracy.
13. The calibration is stored in a non-volatile memory that will not change until the calibration procedure is again performed.

8.6. Program Mode:

The program switch places the controller into the programming mode for price setting, access to all sales information, or to eject coins manually from the changer. Set Program Mode Switch on (up) and press the small pushbutton switch to start the programming mode. Program switch must also be ON for coins to be manually ejected from changer tubes. This switch will reset any sold out items, turn ON for 3 seconds.

Selector switch 1 is used to move up the program menu

Selector switch 2 is used to move down the program menu.

Selector switch 3 is used to enter the selection when pressed for less than 2 seconds. Pressed for 2 seconds or longer can take the controller out of the programming mode. The controller will not return to the program mode until the Program switch is first returned to the off position. This is because the off position is how the program mode is reset.

Menu System: When programming you must first use the first 3 selector switches listed above to maneuver through menus and sub-menus before you will be allowed to accomplish your task. Each menu consists of various items or modes. There are currently two different main menus available. See further for more details on programming.

8.7. Power Indicator:

This LED will illuminate when power is applied to the circuit board.

8.8. System Status Display:

The System Status display is a single digit 7 segment LED located on the ESDI 110100A control board that displays the system status and any error messages, as follows:

Display " 0 "	=	Waiting for customer.
Display " 1 "	=	Vend Item 1.
Display " 2 "	=	Vend Item 2.
Display " 3 "	=	Vend Item 3.
Display " 4 "	=	Vend Item 4.
Display " 5 "	=	Vend Item 5.
Display " 6 "	=	Vend Item 6.
Display " 8 "	=	Tests all segments at start up & reset.
Display " E "	=	Excessive vend time.
Display " F "	=	Flush cycle in progress.
Display " L "	=	Low Water.
Display " U "	=	System is in Lockout. (UV Bad)
Display " C "	=	Calibration mode
Display " P "	=	Pause mode

9.0. Options / Mode Selections (DIP Switch Selectable):

DIP SW 1	Flow Meter / Internal Timer	Off/On
DIP SW 2	UV Flush Cycle Option	Off/On
DIP SW 3	Rinse Cycle Option	Off/On
DIP SW 4	Door Option	Off/On
DIP SW 5	Pause Option	Off/On
DIP SW 6	Lockout Mode	Off/On
DIP SW 7	Option 1	Off/On
DIP SW 8	Option 2	Off/On

9.1. Flow Meter / Internal Timer Selection:

DIP switch 1 controls how the water is metered during the vending cycle. In the OFF position the water is metered through an in-line water flow sensor that sends out pulses related to water flow. The pulses are counted and calibrated and provide a precise and repeatable vending quantity.

In the ON position, water vending is controlled by an on board timer and no flow sensor is required. In order for the time vend to be accurate, however, the water flow must be constant throughout the entire vend cycle. The timer is calibrated and provides a precise and repeatable vending quantity. Refer to section 2.2 for more information.

9.2. UV Flush Cycle Option:

DIP switch 2 enables the Flush cycle option. The flush cycle is provided to periodically discard any hot water that is left standing in the UV lamp assembly, and refresh the vending system in general. This water is discharged out the vend nozzle and into the drain. The flush cycle will turn on every 30 minutes after the last vend cycle, and will run for a period of 3 seconds. When this switch is ON, the flush cycle will be enabled. Refer to section 2.3 for more information.

9.3. Rinse Bottle Option:

DIP switch 3 enables the Rinse Bottle option. When enabled the Rinse cycle will be offered prior to vending water. The amount of water used in the Rinse cycle is approximately 1/16th of the quantity of water purchased. For more information refer to section 2.5 for more information.

9.4. Door Option: (Not available on Model 110100A-Master/Slave Controller)

DIP switch 4 enables the Door option. The Door option is used when the vend nozzle is kept behind a closed door. Enabling this switch will allow the door to open prior to vending water, and to close immediately after. For more information, refer to section 2.6 for more information.

9.5. Pause Mode Option:

DIP switch 5 enables the Pause mode of operation. In the Pause mode, the Vend switch is used not only to begin the vending of water, but to pause the vending for a short period of time. Refer to section 2.4 for more information regarding the Pause mode.

9.6. Lockout Mode:

DIP switch 6 determines how the controller will react to a Lockout condition. Refer to section 2.7 for more information.

9.7. Option 1:

DIP switch 7 determines if the vend switch will be used. In the ON position, the vend switch is not used and vending will begin upon activating the Selection switch. If a vend switch is used, place this switch in the OFF position.

9.8. Option 2:

DIP switch 8 is used for the Master controller only. In the ON position, a Low Water detection will shut down the entire system including the slave boards until water is available for vending. In the OFF position a low water condition will only disable the Master board will not shut down the entire machine.

6 VOLUME - 6 PRICE WATER VENDING MACHINE

Using ESDI Model 110100 , Multiprice Vend Control Board

NOTE: This diagram does not show the exact placement of components. It is for reference only.

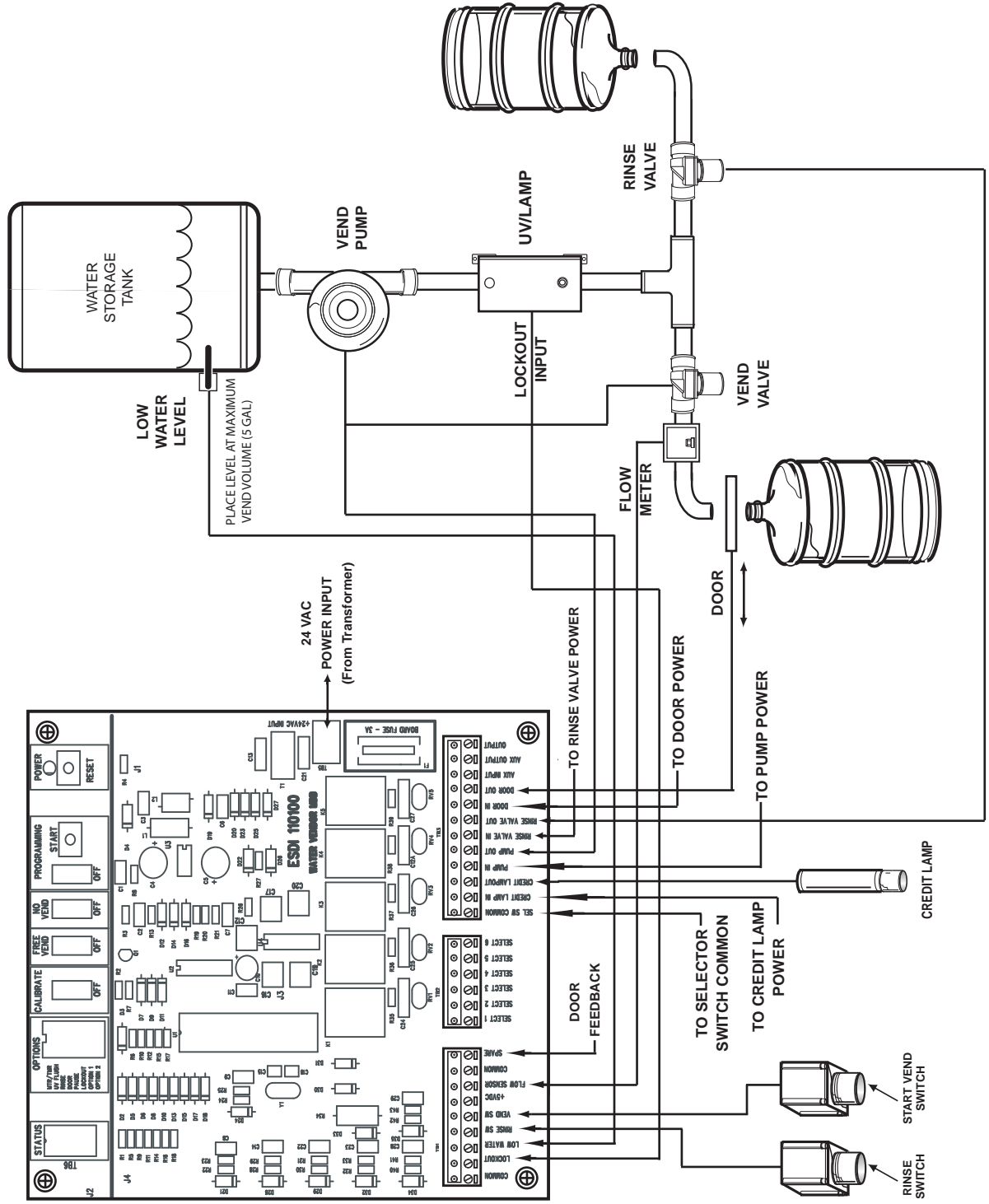

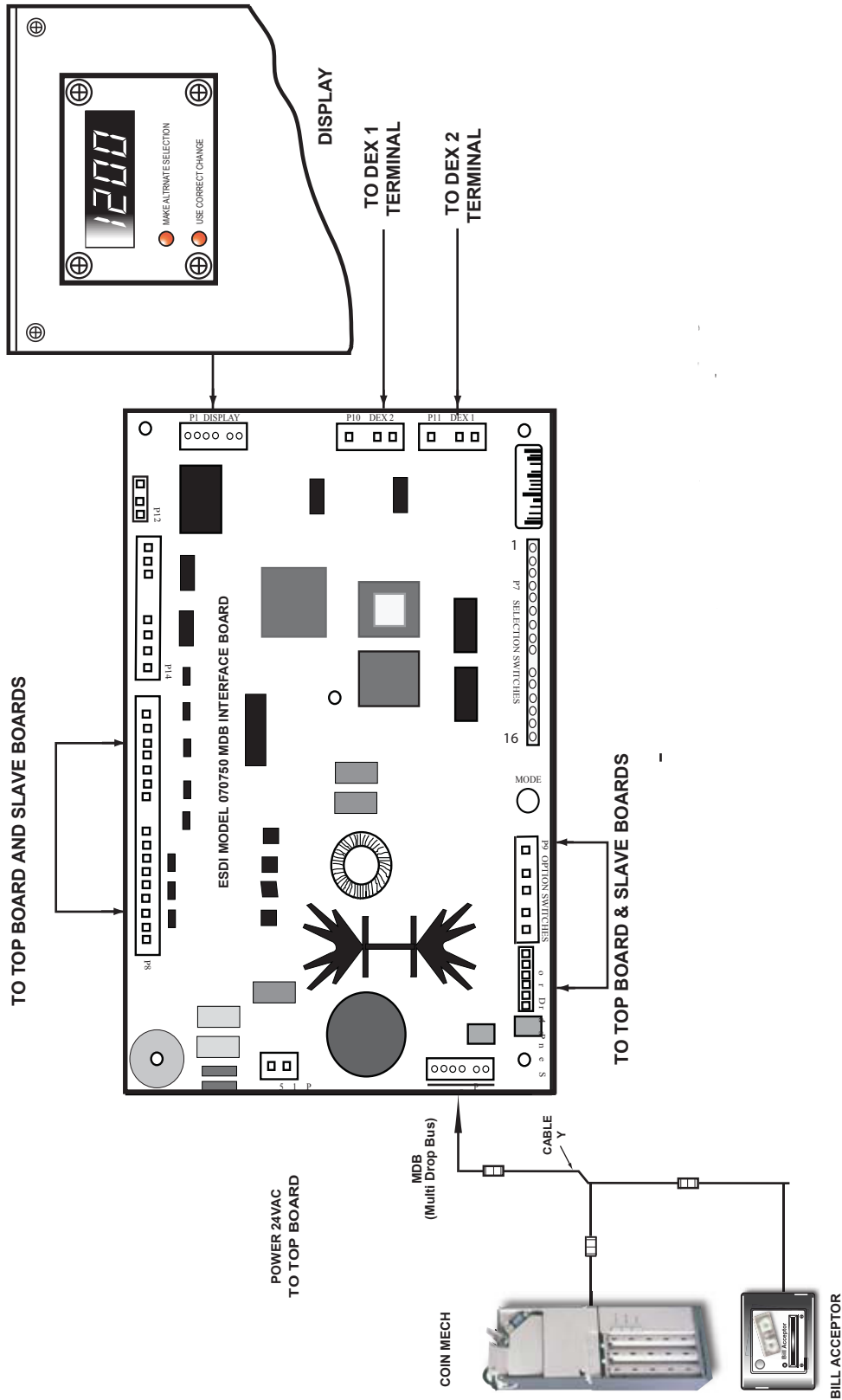

ESDI MODEL 110100 MDB WATER VENDING CONTROLLER (Rear View)

ELECTRONIC SYSTEMS DESIGN, INC
 1010 North MacLay Avenue, San Fernando, California 91340 U.S.A.
 PHONE: (818) 365-0864 FAX: (818) 365-1308 www.esdi.net

ESDI MODEL 110100A - WIRING DIAGRAM
 April 18, 2012

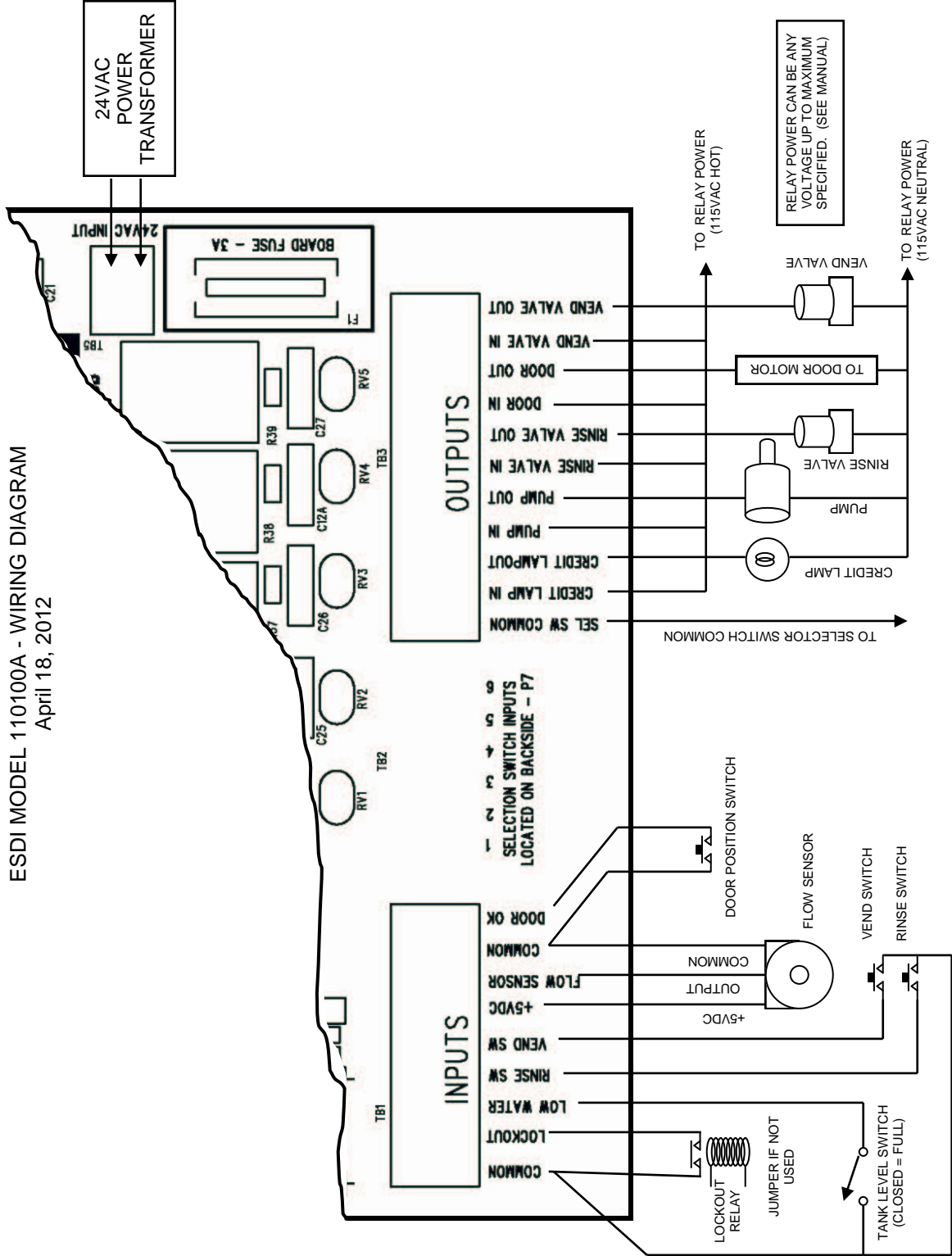

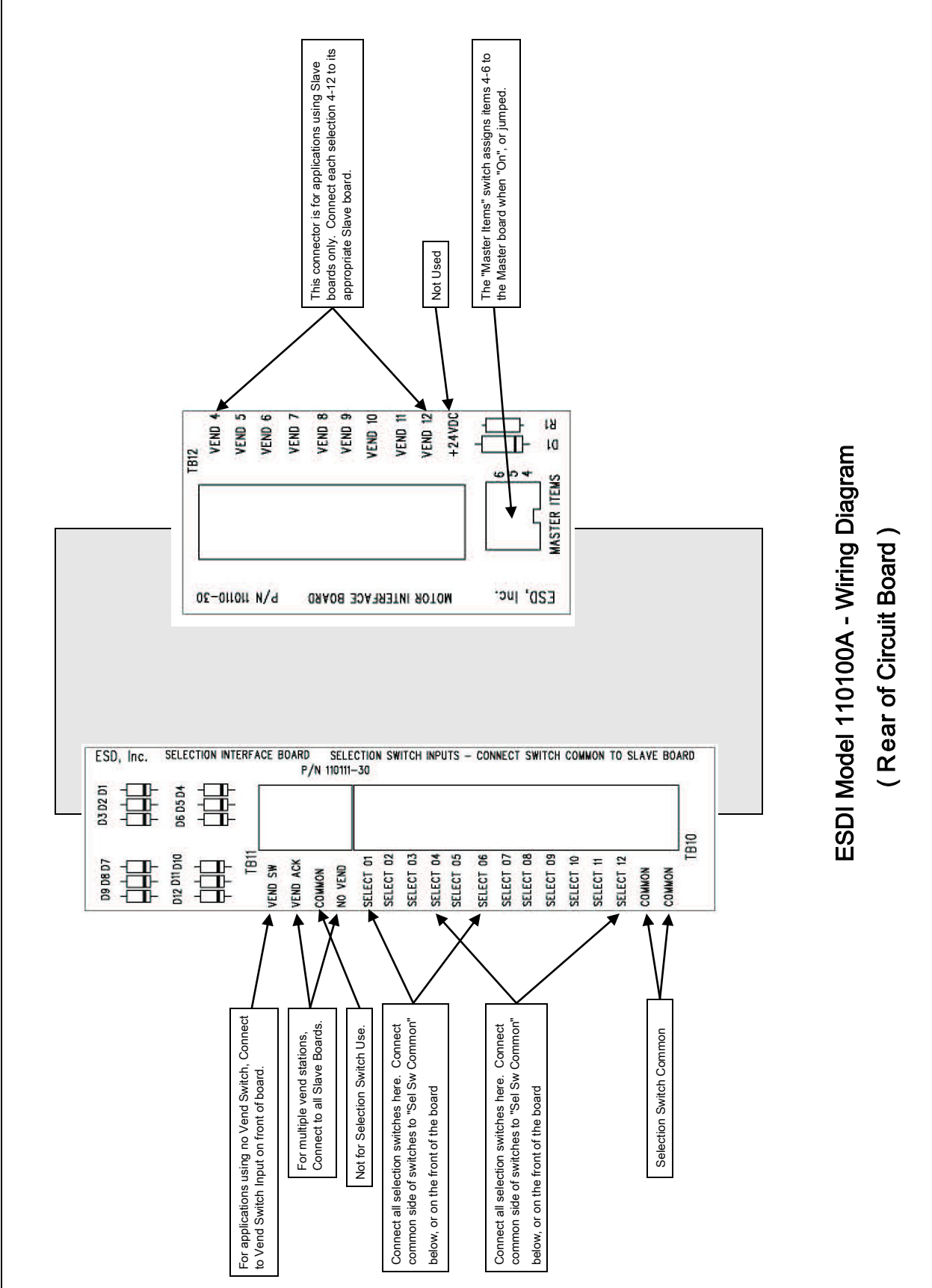

**ESDI Model 110100A - Wiring Diagram
(Rear of Circuit Board)**

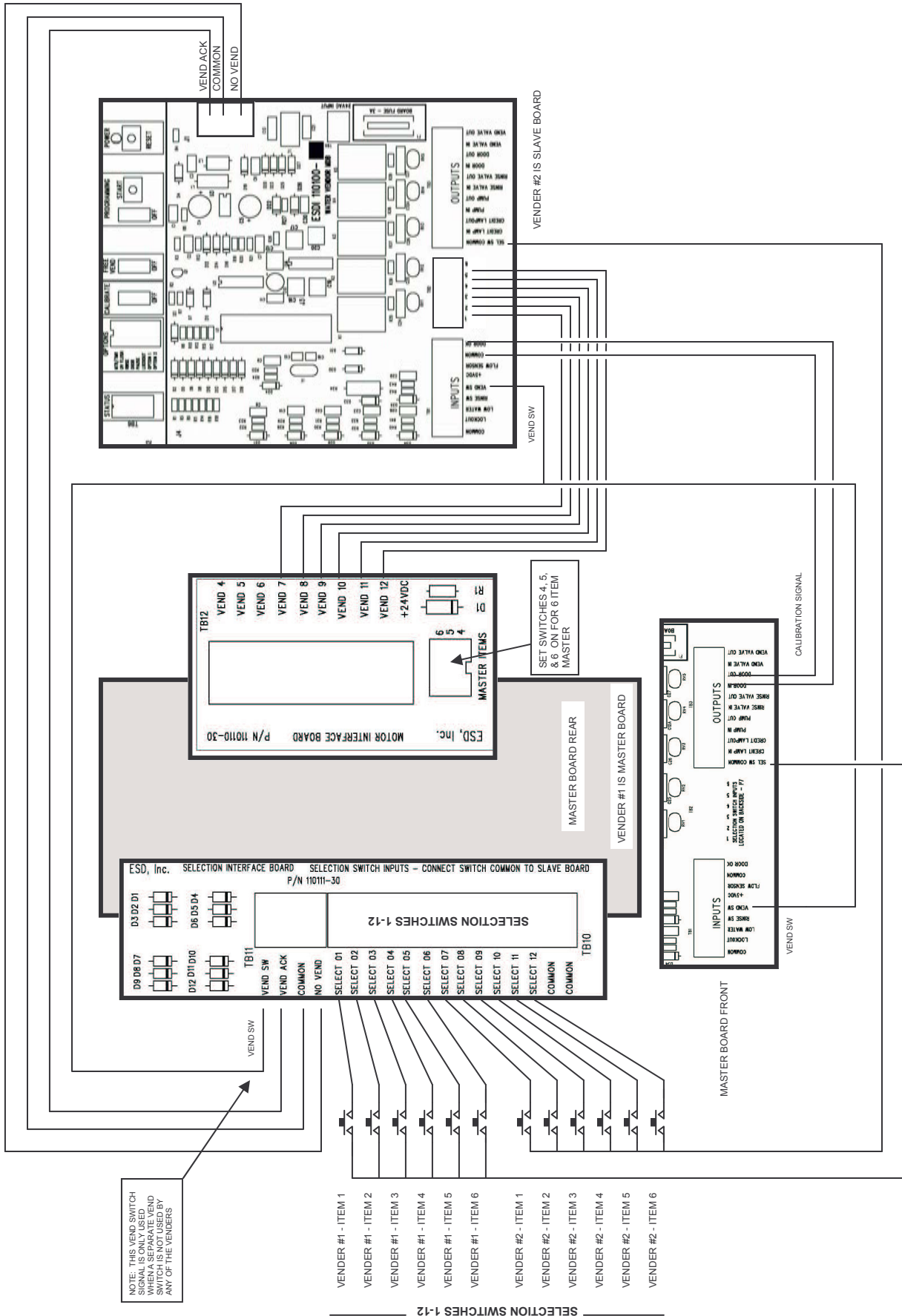

NOTE: THIS VEND SWITCH SIGNAL IS ONLY USED WHEN A SEPARATE VEND SWITCH IS NOT USED BY ANY OF THE VENDERS

- VENDER #1 - ITEM 1
- VENDER #1 - ITEM 2
- VENDER #1 - ITEM 3
- VENDER #1 - ITEM 4
- VENDER #1 - ITEM 5
- VENDER #1 - ITEM 6
- VENDER #2 - ITEM 1
- VENDER #2 - ITEM 2
- VENDER #2 - ITEM 3
- VENDER #2 - ITEM 4
- VENDER #2 - ITEM 5
- VENDER #2 - ITEM 6

SELECTION SWITCHES 1-12

ESDI Models 110100A (Master) & 110150A (Slave) - Wiring Diagram For Two Vend Stations

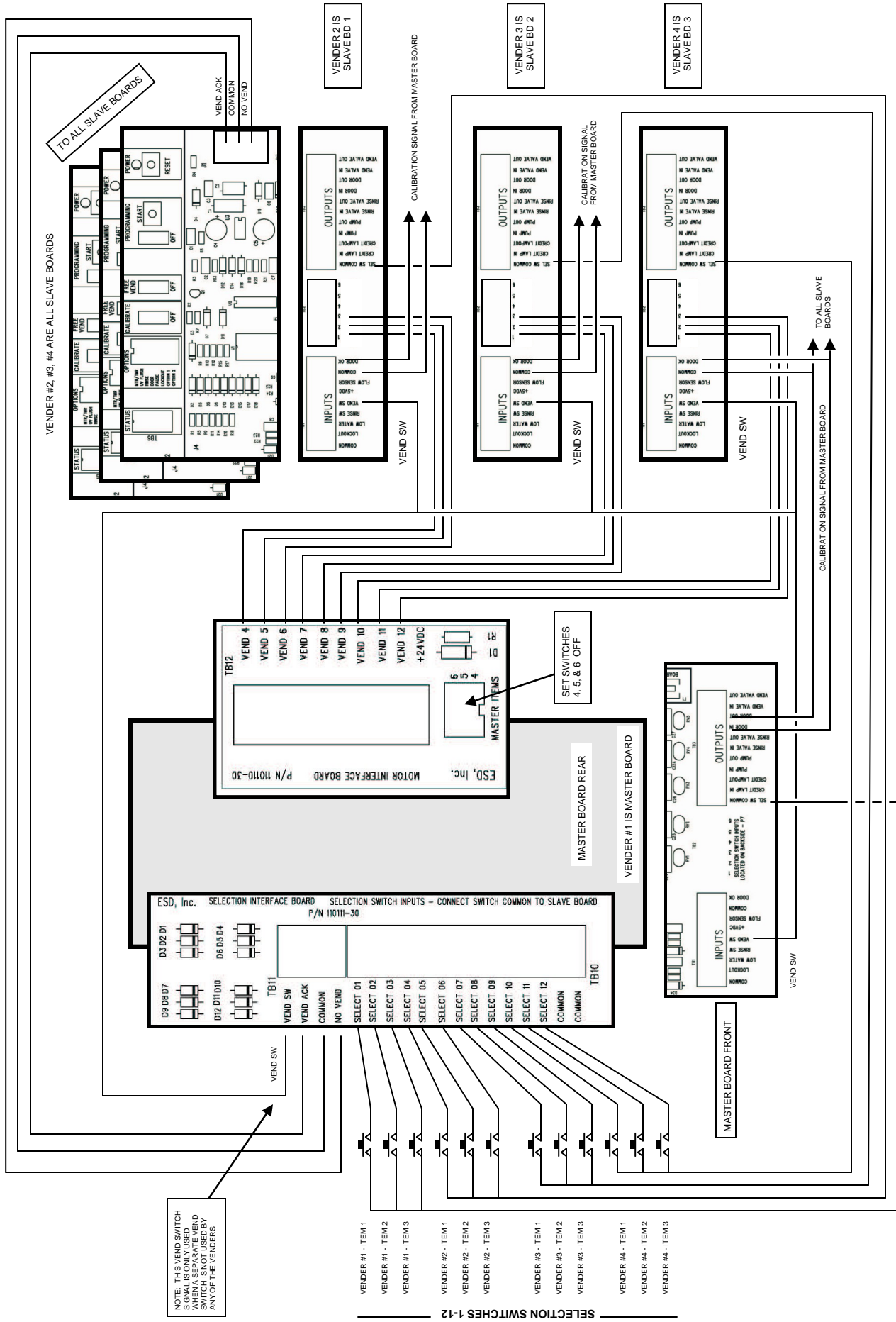

ESDI Models 110100A (Master) & 110150A (Slave)
Wiring Diagram For Four Vend Stations - Three (3) Selections Each